

ELVITA



User manual
Electric cooker
CGS3723V

Thank you

for your trust and the purchase of our product. This user manual is supplied to help you use this product. The instructions should allow you to learn about your new product as quickly as possible.

Make sure you have received an undamaged product. If you do find transport damage, please contact the seller from which you purchased the product, or the regional warehouse from which it was supplied.

ELVITA

Language: en-GB, Publication date: 2020-09-07

This document and its content, including written material and images, are the property of Elon Group AB. You may not copy, reproduce, modify, republish or distribute this document or any of its content without express written permission from Elon Group AB. © 2020, Elon Group AB. All rights reserved.

CONTENTS

SAFETY	5
Admonitions	5
Safety for children and people with disabilities.....	5
General safety.....	5
Safety labels.....	6
Disposal.....	6
GETTING STARTED	7
Installation.....	7
Before you use the cooker	7
Hob overview	7
Cooker controls	7
Open the door lock	8
Accessories.....	8
COOKING WITH THE HOB	9
Hob surface.....	9
Suitable cookware	9
Turn on and off the cooking zones	9
Save energy	9
COOKING WITH THE OVEN	11
Cooking modes	11
Top heater.....	11
Bottom heater.....	11
Top and bottom heater	11
Grill	11
Large grill	11
WaterClean	11
Turn on and off the oven	11
Change oven temperature	12
Change oven cooking mode	12
Oven cooking mode guide	12
Wire guides	13
Grilling recommendations	13
Roasting recommendations	13
Baking recommendations	13
CLEANING	15
Clean the hob surface.....	15
Clean glass surfaces	15
Clean stainless steel surfaces	15
Clean enamel surfaces	15
Clean plastic parts and lacquer-coated surfaces	16

Clean the oven	16
Use the WaterClean programme	16
TROUBLESHOOTING	17
General troubleshooting	17
Oven troubleshooting	17
Replacing parts	17
Replace the oven light bulb	17
Replace the oven door	18
Remove and install the oven door glass pane	19
Remove and install the wire guides	19
INSTALLATION	20
Cooker placement	20
Secure the cooker to a wall	20
Adjust the height of the cooker	21
Level the cooker	21
Connect the mains power	22
APPENDIX	24
Specifications	24
EU directives and standards	24

SAFETY

Carefully read the instructions before you install and use the product. Save the instructions and keep them near the appliance for future reference.

Admonitions

**WARNING!**

Used when there is a risk for personal injury.

**CAUTION!**

Used when there is a risk for damage to the appliance.

**NOTE!**

General information that you should be aware of.



Helpful tips that you may find useful.

Safety for children and people with disabilities

**WARNING!**

- Keep children younger than 8 years old away from the product unless continuously supervised.
- Only let the following groups use the product if they are supervised or if instructions are provided to them about how to use the appliance in a safe way. They must understand the hazards involved.
 - Children. (Children younger than 8 years old must be continuously supervised.)
 - Persons with reduced physical, sensory or mental capabilities.
 - Persons with lack of experience and knowledge.

**WARNING!**

- Do not let children play with the product.
- Do not let children clean the product without supervision.

**WARNING!**

Only use hob guards designed or recommended by the manufacturer. The use of inappropriate hob guards may cause accidents.

General safety

**WARNING!**

Do not use the product for other purposes than cooking, for example room heating.

**WARNING!**

Always supervise the cooking process continuously.

**WARNING!**

Risk of fire!

- Do not store items on the cooking surface.
- Do not store combustible, explosive, volatile or temperature-sensitive items (such as paper, dish cloths, plastic bags, cleaners or detergents and spray cans) in the oven's storage drawer, as they can ignite during over operation and cause a fire.
- Unattended cooking on a hob with fat or oil may result in a fire.

Never try to put out a fire with water. Instead turn off the product and cover the flame with, for example, a lid or a fire proof blanket.

- Make sure the air vents are never covered or obstructed in any way.

**WARNING!**

Risk of burns!

- Cookware and accessible parts of the product may become very hot during use. Be careful not to touch hot parts.
- The oven door may become very hot during operation.
- Do not place metal objects like knives, forks, spoons, or lids on the cooking zones, as these objects can become very hot.

**WARNING!**

Risk of electric shock!

- If the cooking surface is cracked, turn off the product immediately and disconnect it from the mains. Do not use or touch the product.
- Keep power cords of other appliances at a safe distance so that they are not caught in the oven door, as the cords may become damaged and cause short-circuit.

**CAUTION!**

Do not line the oven walls with aluminium foil. Aluminium foil prevents air circulation in the oven, hinders the cooking process, and ruins the enamel coating.

Safety labels

These safety labels can be found on the product.



Caution! Risk of tilting.



Warning! Stabilising means must be installed to prevent tipping.

Disposal



Dispose of packaging in an environmentally-friendly manner.

This appliance is marked in compliance with European Directive 2012/19/EU, Waste Electrical and Electronic Equipment (WEEE). The symbol on the product or on its packaging indicates that this product should not be treated as household waste. Instead it shall be handed over to the applicable collection point for the recycling of electrical and electronic equipment.

By ensuring this product is disposed of correctly, you will help prevent potential negative consequences for the environment and human health, which could otherwise be caused by inappropriate waste handling of this product. For more detailed information about recycling of this product, please contact the relevant municipal body in charge of waste management, your household waste disposal service or the store where you purchased the product.

GETTING STARTED

Installation

See section "Installation", page 20.

Before you use the cooker

1. Remove all transport packaging and equipment from the cooker.
2. Clean all accessories and utensils with warm water and regular detergent. Do not use any abrasive cleaners.
3. Turn on all cooking zones on to the maximum power for 3 to 5 minutes without any cookware on them. As the cooking zones heat up, some smoke may appear on the cooking hob surface. By heating up the hob once before using it for the first time, the your hob becomes more resistant from dirt sticking onto it.
4. Heat up the oven without food to 275° C for 60 minutes. Ventilate the room as the cooker will omit the characteristic smell of a new appliance.

WARNING! Make sure all packaging remnants have been removed from the cooking compartment.

Hob overview

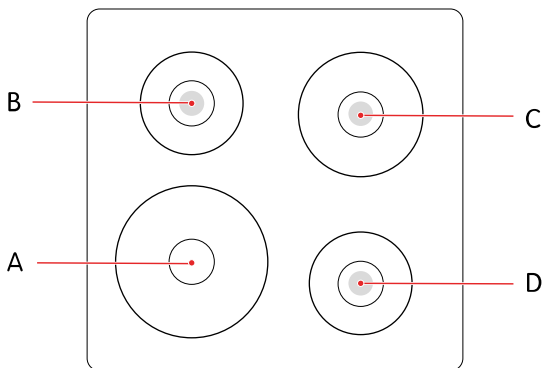

- A. Front left cooking zone
- B. Rear left cooking zone (rapid)
- C. Rear right cooking zone (rapid)
- D. Front right cooking zone (rapid)

Rapid cooking zones use more power and can heat up quicker than other cooking zones.

Cooker controls

Turn the selectors to control the cooker.

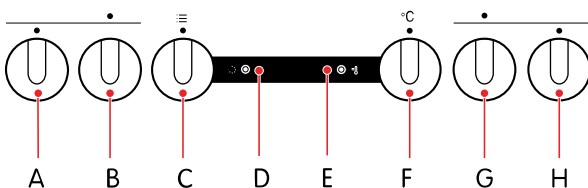

- A. Front left cooking zone power selector
- B. Rear left cooking zone power selector
- C. Oven cooking mode selector
- D. Operation indicator light (yellow)
- E. Temperature indicator light (red)
- F. Oven temperature selector
- G. Rear right cooking zone power selector
- H. Front right cooking zone power selector

Lights

The operation indicator light is on when the oven or one of the hobs are on. The temperature indicator light turns on when the oven heats up and turns off when the oven has reached the selected temperature.

Open the door lock

The oven door locks automatically when you close it.

1. Push the door lock gently to the right with your thumb.
2. Pull the oven door while still pushing the door lock.

Accessories

The cooker is supplied with some useful accessories to improve your cooking experience.

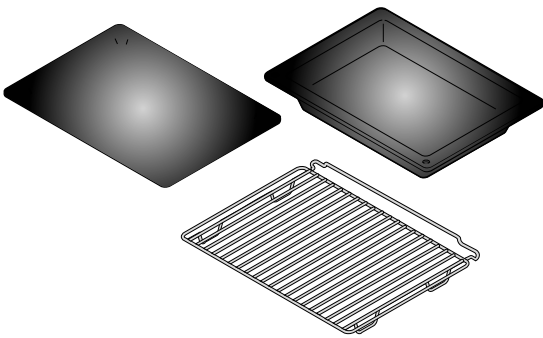

Shallow trays

For baking pastries or as a drip tray.

Extra deep tray

For roasting large amounts of vegetables and meat or preserving food.

Grid

For grilling meat or fish.

COOKING WITH THE HOB

Hob surface

Here is some advice on how to use and maintain the hob surface.

**WARNING!**

Risk of fire! Overheated fat and oil may ignite. Never leave cooking with fat or oil unattended.

- Make sure the cooking zone and the bottom of the cookware are clean and dry before use to ensure better heat conduction and prevent damage.
- Do not place wet cookware or lids covered in steam on the cooking zones. Moisture may damage the cooking zones.
- Do not cool down the hot cookware by placing it on the cooking zones that were not in use. The condensed water that appears under the cookware bottom may aid corrosion.

**NOTE!**

Prolonged use of the cooking zones may cause discoloration of the edge of the cooking zone. Such discoloration does not affect function and is not covered by warranty.

Suitable cookware

For the best results and to prevent damage, make sure you use suitable cookware.

- Use quality cookware with a flat and stable bottom.
- Make sure the cookware bottom fits the diameter of the cooking zone.



When purchasing cookware, note that the indicated diameter usually refers to the upper edge or the lid, which is normally larger than the diameter of the bottom.

- Cookware made of tempered glass, with a special ground bottom can be used if its diameter fits the cooking zone. Cookware with larger diameter may crack due to thermal tension.

Turn on and off the cooking zones

1. Rotate the knob to turn on the cooking zone.
You can set the heating power in steps from 1 to 6.
2. Turn off the cooking zone by rotating the knob to 0.



Turn off the cooking zone 3 to 5 minutes before the food is ready to make use of the residual heat and save energy.

**NOTE!**

Cooking zones indicated with a red dot in the middle are rapid cooking zones. Rapid cooking zones use more power and can heat up quicker than other cooking zones.

Save energy

Here are some tips on how you can save energy.

- Make sure the cookware bottom fits the diameter of the cooking zone. If the cookware is too small, a part of the heat is lost and the cooking zone may be damaged.
- Use cookware that fits the amount of food you are cooking. Using larger cookware than required consumes more energy.
- When possible, cover the cookware with a lid.
- If a dish takes long time to cook, use a pressure cooker.

- Vegetables, potatoes, and so on, may be cooked in a smaller amount of water. The food will cook just as well, as long as the cookware is tightly closed with a lid. After bringing the water to a boil, reduce the heat to a level that just suffices to maintain a slow simmer.

COOKING WITH THE OVEN

- Use dark, black silicon coated or enamel coated baking trays. They transmit heat better.
- Cooking many types of pastries one after another saves energy since the oven is already hot. Heating an oven that has cooled down uses more energy.
- Steam can sometimes form on the inside of the oven during cooking. The steam may condense on the door and the lid of the cooker. This is normal behaviour and does not affect the operation of the cooker. Wipe of any condensed water with a cloth.
- If you leave the dish in the oven after it has finished cooking steam may evaporate from it and condense on the front panel and the oven door.



You can turn off the oven about 10 minutes before the end of the cooking process. This will save energy as the already built up heat is used.

Cooking modes

Top heater



Use this oven mode to brown the upper side of food (final browning). The top heater will radiate heat on the upper side of the food. Recommended temperature: 180°C.

Bottom heater



Use this oven mode to brown the lower side of food. The bottom heater will radiate heat on the lower side of the food. Recommended temperature: 180°C.

Top and bottom heater



Use this oven mode to cook meat or pastry that can only be baked or roasted at a single height level. The top and bottom heaters will radiate heat evenly in the oven. Recommended temperature: 200°C.

Grill



Use this oven mode to grill small amounts of open sandwiches, beer sausages or to toast bread. Only the grill heater is on when using this mode. Recommended temperature: 230°C.

Large grill



Use this oven mode to grill small amounts of open sandwiches, beer sausages, meat or to toast bread. The grill heat and the upper heater are both on when using this mode. Recommended temperature: 230°C.

WaterClean



Use this oven mode to remove stains and food residues from the oven. Only the bottom heater will radiate heat. The programme takes 30 minutes. Recommended temperature: 70°C.

Turn on and off the oven

1. Turn the oven mode selector to any of the cooking modes to turn it on.
2. Turn the oven mode selector to **0** to turn it off.

Change oven temperature

Select a suitable temperature for what you are cooking.

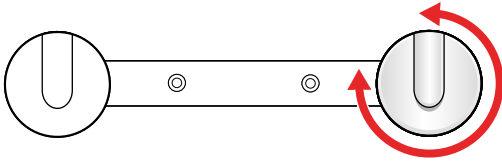

1. Turn the temperature selector clockwise to increase the temperature or anticlockwise to lower the temperature.
CAUTION! Do not turn the selector below the zero position. This can damage the thermostat.
 The temperature range is 50-275°C.

Change oven cooking mode

Select the suitable cooking mode for what you are cooking.

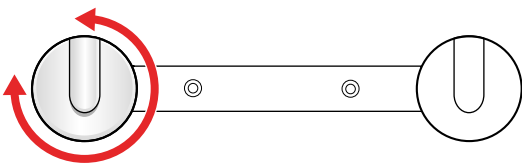

1. Turn the cooking mode selector clockwise or anticlockwise to switch between the available modes.



The cooking mode can also be changed during cooking.

Oven cooking mode guide

Find the most suitable oven cooking mode for your needs by using the following table.

Cooking method	Food type	Oven cooking mode
Roast	Meat	
Grill	Open sandwiches, beer sausages	
	Open sandwiches, beer sausages, meat	
Brown	Upper side of food	
	Bottom side of food	
Bake	Pastries on a single level	
Toast	Bread	

Wire guides

Wire guides allow you to choose between 4 different levels when you insert a grid or a tray into the oven. The levels/guides are counted from the bottom and up.

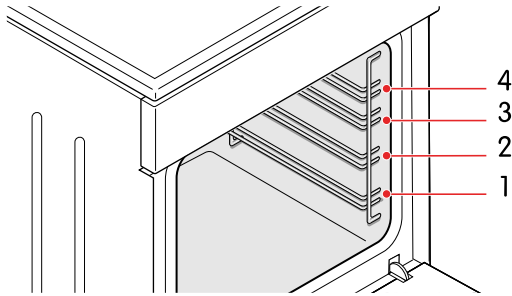

The oven is safe to use both with and without the guides.



CAUTION!

Do not place baking trays or other cookware on the bottom of the oven.

Grilling recommendations

Use these recommendations when grilling.



WARNING!

Only use the grill with the oven door closed.



WARNING!

Use oven mitts or meat tongs. The grill heater, grid, and other oven accessories get very hot during grilling.

- Preheat the grill for about 5 minutes before you use it.
- Observe the food regularly. The food may burn quickly because of the high temperature.
- Smear the grid with oil to prevent the meat from sticking when grilling directly on it. Use the 4th guide.
- Insert the drip tray in to the 1st or 2nd guide.
- Make sure there is enough liquid in the tray when using a baking tray. Otherwise the food may burn.
- Turn the meat.
- Clean the oven, the accessories, and the utensils when you have finished grilling.

Roasting recommendations

Use these recommendations when roasting.

- Use enamel coated, tempered glass, clay, or a cast iron pan or tray.



NOTE!

Do not use stainless steel trays. They strongly reflect heat.

- Use enough liquid when cooking to prevent the meat from burning.
- Cover the meat to keep it juicy.

Baking recommendations

Use these recommendations when baking.

- Preheating is recommended.
- You can bake biscuits and cookies in shallow baking sheets on several levels (second and third) at the same time.

**NOTE!**

The biscuits or cookies on the upper baking sheet may be ready sooner than the ones on the lower one.

- Always place the baking trays on the grid. Remove the grid if you are using the supplied baking sheet.

**CAUTION!**

Do not insert the deep baking tray into the first guide.

- Make biscuits of similar thickness to make sure that they brown evenly.
- Baking accessories may change form as they get hot. This does not affect their functions and they will return to their original form when they cool down.

CLEANING

Make sure to clean your product regularly to make it last longer and keep a good appearance.

**WARNING!**

Do not let children clean the product without supervision.

**WARNING!**

Risk of electric shock!

- Before cleaning, disconnect the product from the mains.
- Do not use steam cleaners or high pressure cleaners to clean the product, as this may result in electric shock.

**CAUTION!**

Always wait for the product to cool down before cleaning.

Clean the hob surface

- Clean the area around the cooking zones with hot water and some washing-up liquid. For stubborn dirt, use a steel wool pad soaked with detergent. Then rinse and wipe dry.
- Clean and maintain the cooking zones with regular cleaners and commercially available conditioners. If the cooking zone is slightly warm, the cleaner penetrates the pores more efficiently.

**NOTE!**

Always clean the cooking zones after use. Liquids containing salt, boiled-over liquids and moisture can cause damage.

- The cooking zone rims are made of stainless steel that may take on a yellowish hue after some time of use. Clean the rims with regular metal cleaners. Do not use aggressive dishwashing accessories as they may cause scratches.

Clean glass surfaces

Clean glass surfaces with equipment and agents intended for cleaning glass, mirrors, and windows.

**CAUTION!**

Do not use rough abrasive cleaners or sharp metal scrapers as they could crack the surface and cause the glass to break.

Clean stainless steel surfaces

Clean stainless steel surfaces with a mild detergent and a soft sponge that will not scratch the surface.

**CAUTION!**

Do not use abrasive cleaners or cleaners containing solvents as they may damage the surface.

Clean enamel surfaces

Clean enamel surfaces with a damp sponge. Remove fatty stains with warm water and special detergent for enamel.

**CAUTION!**

Do not clean enamel surfaces with abrasive cleaners or tools as they may cause permanent damage.

Clean plastic parts and lacquer-coated surfaces

Immediately remove any stains on plastic parts and lacquer-coated surfaces with a soft non-abrasive cloth and some water. You may also use cleaners and cleaning tools intended for plastic and lacquer-coated surfaces. Follow the manufacturer's instructions.

**CAUTION!**

Do not use abrasive cleaners, abrasive tools, or alcohol-based cleaners.

Clean the oven

Clean the oven cavity regularly.

**CAUTION!**

Do not lean against the open door when cleaning the oven cavity. Never stand on the open oven door and do not let children sit on it. The oven door hinges may be damaged under excessive load.

**CAUTION!**

Do not use abrasive agents. They will scratch enamel coated surfaces.

- Clean the oven walls with a damp sponge and detergent. Use a special enamel detergent for burned stains.
- Wipe the oven dry carefully after cleaning it.
- Clean the wire guides and telescopic guides using a conventional detergent.

**CAUTION!**

Do not clean the telescopic guides in a dishwasher.

- Clean the oven utensils with a sponge and detergent. You can use special detergents for rough stains or burns.

Use the WaterClean programme

Use the WaterClean programme to easily remove stains and food residues from your oven.

**CAUTION!**

Make sure the oven has cooled down before you start the WaterClean programme.

1. Turn the cooking mode selector to .
2. Turn the temperature selector to 70°C.
3. Pour 0.6 l water into a baking tray and place it in the lower guide.
4. Let the programme run for 30 minutes. The food residues will soften.
5. Clean the oven enamel walls with a damp cloth.

TROUBLESHOOTING

You can solve many minor problems with help from the troubleshooting information. If the problem persists, do not try to repair the product in other ways than mentioned in this manual.



WARNING!

Risk of electric shock!

- Do not attempt to perform any repairs yourself. Tampering with the product and non-professional repair may cause injury or damage to the product. It also makes the warranty invalid. Instead, contact a service technician.
- Do not replace the power cord yourself. If the power cord is damaged, it must be replaced by the manufacturer or authorised technicians to avoid hazard.

General troubleshooting

Use this table to solve general problems with your cooker.

Problem	Solution
The main fuse in your home trips often.	Make sure the power of all switched-on appliances does not exceed the capacity of the power mains in your home. Contact a service technician.

Oven troubleshooting

Use this table to solve problems with your oven.

Problem	Solution
The oven lighting does not work.	section "Replace the oven light bulb", page 17
The food is undercooked.	Make sure you have selected the right temperature and cooking mode. Make sure the oven door is closed.

Replacing parts

Replace the oven light bulb

When the light bulb breaks, replace it with a halogen light bulb G9, 25 W.



WARNING!

Risk of electric shock! Before replacing the light bulb always disconnect the product from the mains.



NOTE!

The light bulb is not covered by warranty because it is a consumable item.

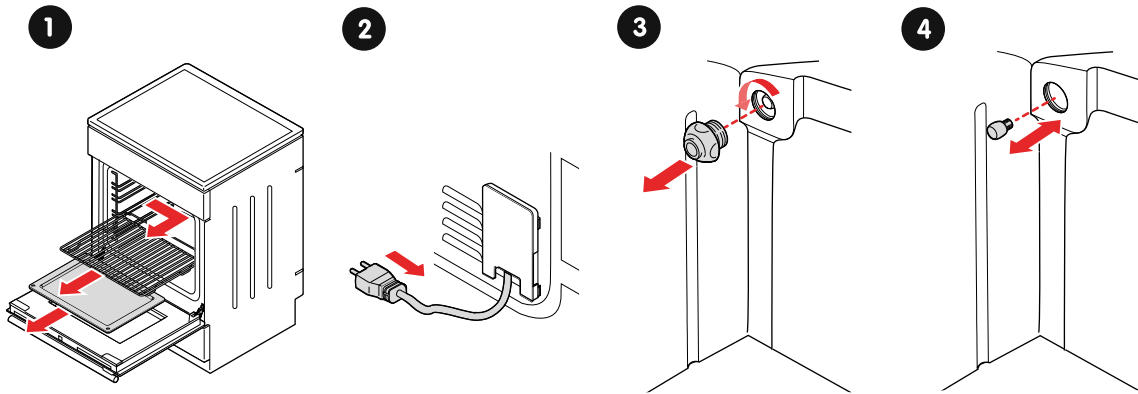

1. Remove the grid, guides and trays.
2. Disconnect the cooker from the mains power.
3. Remove the bulb cover.
4. Replace the bulb.
WARNING! Use protection when you remove the old light bulb to avoid burning yourself.
CAUTION! Do not damage the enamel surface.
5. Install the cover.
6. Connect to cooker to the mains power.

Replace the oven door

Remove and replace the oven door if it is broken or if you need to remove the oven door glass pane. See section "Remove and install the oven door glass pane", [page 19](#).

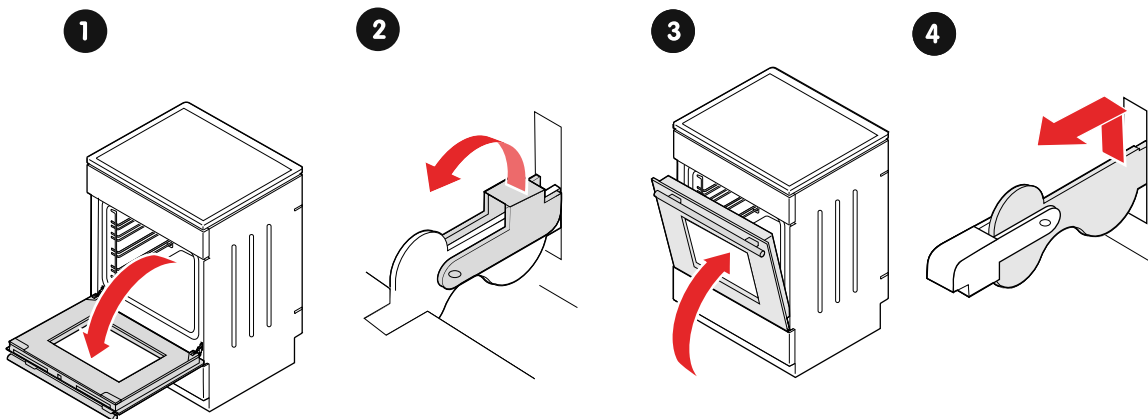

1. Open the oven door fully.
2. Fold the latches of the door hinges.
3. Fold the door to a 15° angle so that the latches fit together with the door hinges.
4. Remove the door: pull out the hinges from the openings.

Install in the reverse order.



WARNING!

Make sure the hinge latches are correctly placed in the side laths of the door before you install it. This prevents the hinges from suddenly closing, which can injure you or damage the door.

Remove and install the oven door glass pane

Remove the oven door glass pane if it is broken or if you want to clean it.

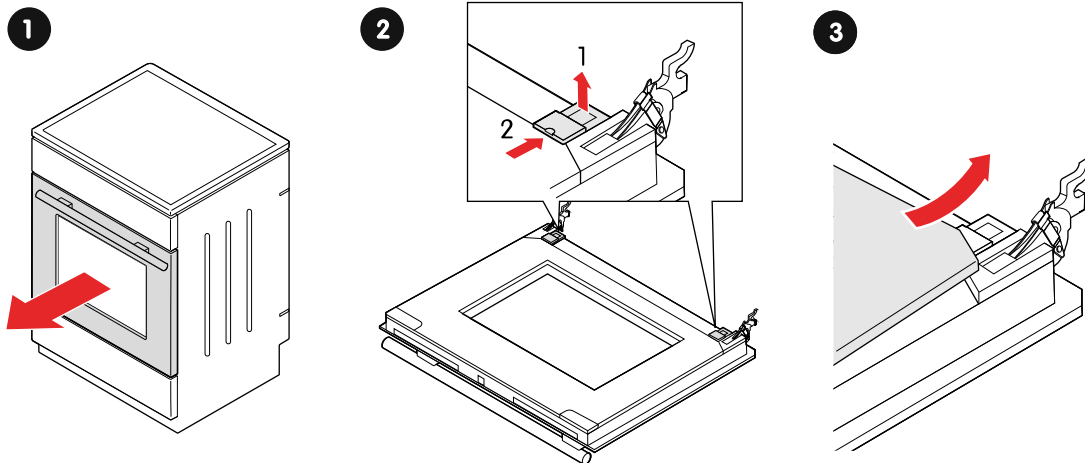

1. Remove the oven door from the appliance (section).
2. Lift the supports a little and pull them out.
3. Lift up the lower end of the glass pane and remove it.

Install in the reverse order.



NOTE!

The markings (semicircle) on the door and the glass pane should overlap.

Remove and install the wire guides

Use this procedure to remove and install the wire guides.

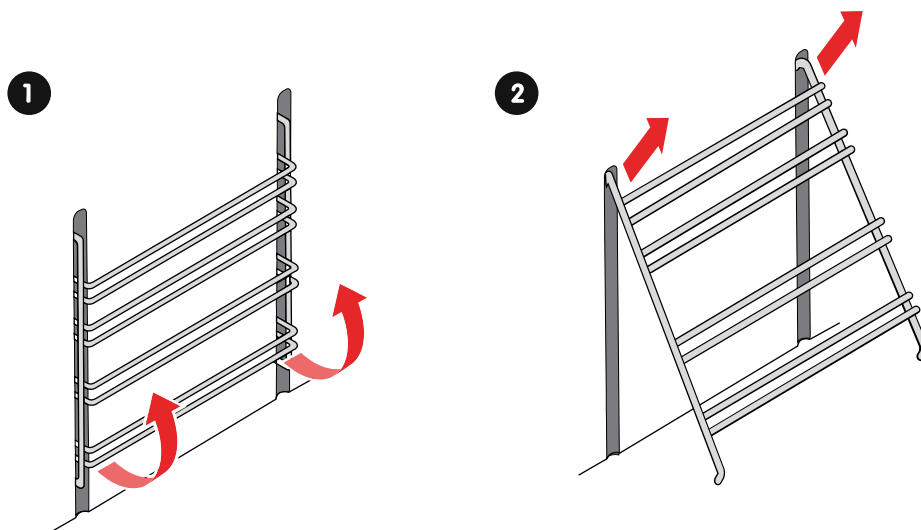

1. Pull the bottom side of the guides out from the oven wall.
2. Pull out the guides from the holes at the upper side.

Install the guides in the reverse order.

INSTALLATION

Cooker placement

Make sure to place the product considering the measurements and other factors described in this section.

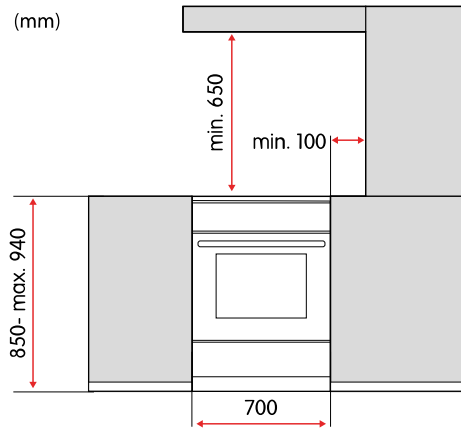

WARNING!

Risk of fire!

- Make sure the floor and the adjacent walls are temperature resistant to at least 90°C.
- Do not install the product behind a decorative door, as it may become overheated.



WARNING!

The product is intended to be placed directly on the floor, without any support or plinths.



CAUTION!

Do not install the product near powerful heat sources, such as solid fuel stoves, as the high temperature may damage the product.

Secure the cooker to a wall

Securing the cooker to a wall will prevent it from tipping over.

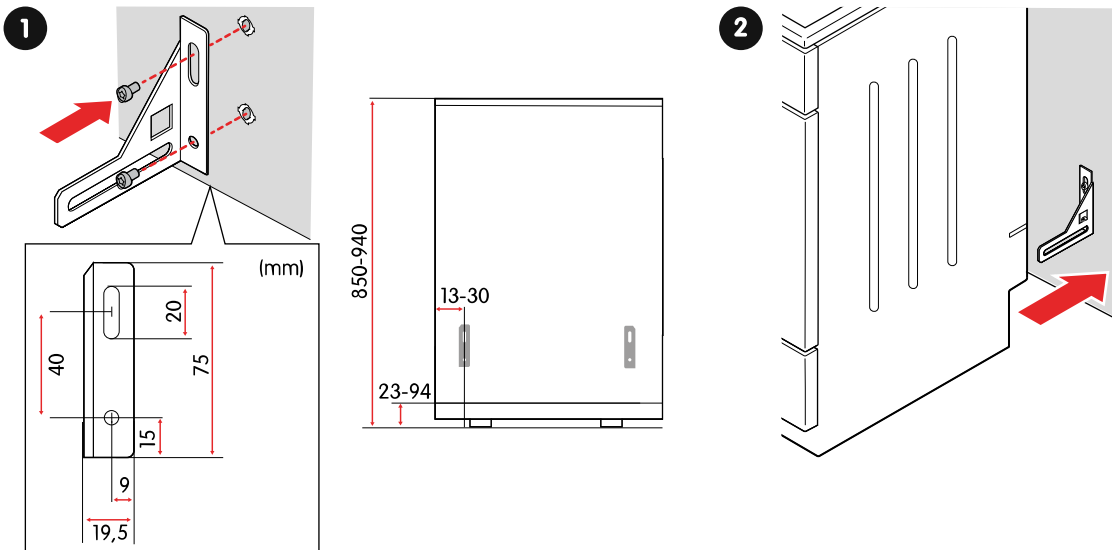

1. Fasten the bracket to the wall using the supplied screws and anchors.
WARNING! If the supplied screws or anchors are not suitable for the wall, make sure you use ones that will ensure a secure installation on the wall.
2. Position the cooker to the bracket and fasten it.

Adjust the height of the cooker

You can adjust the height of the cooker from 850 mm to 940 mm.

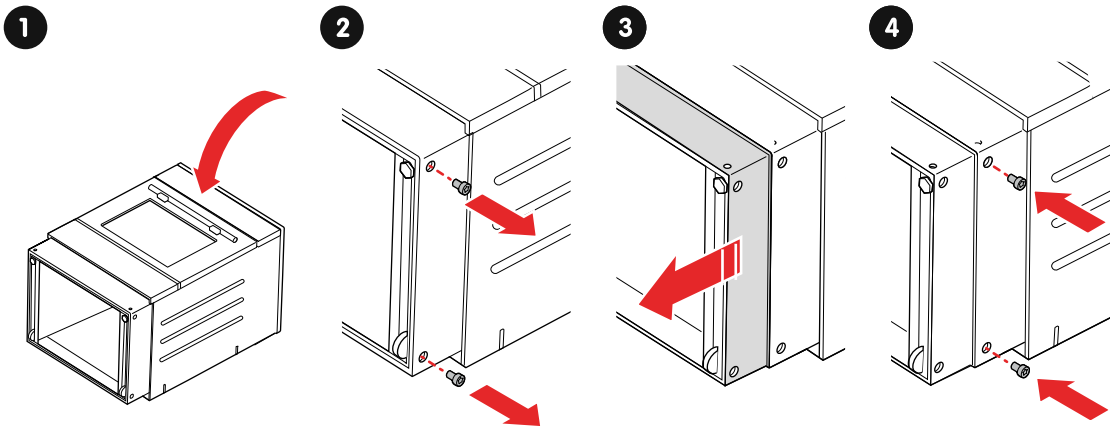

1. Lay the cooker down on the floor on its back.
2. Unscrew the screws.
3. Adjust the height.
4. Screw the screws back in.

Level the cooker

Level your cooker by adjusting the height of the the front feet and the rear wheels individually.



WARNING!
The cooker must be installed horizontally levelled.

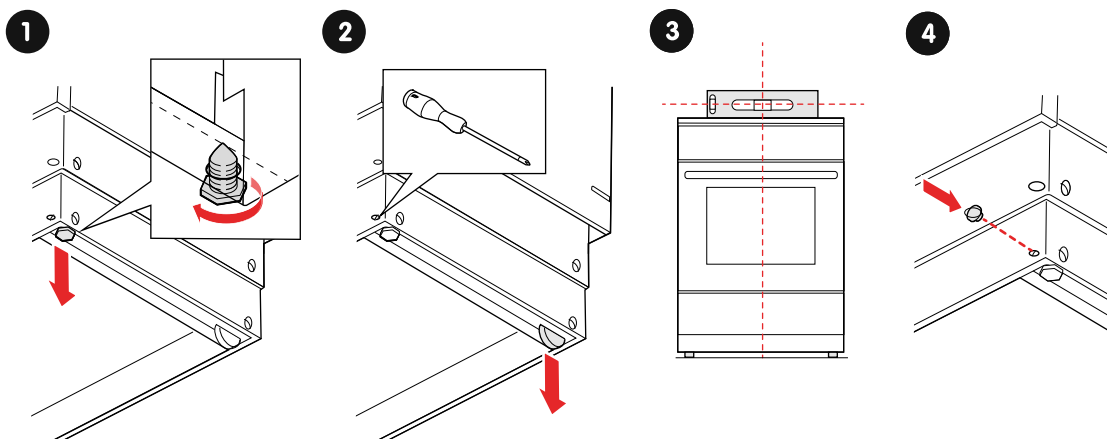

1. Turn the front feet to adjust the height.
2. Turn the wheel adjustment screws to adjust the height of the rear wheels.
3. Place a spirit level on top of the cooker to check the horizontal position. Adjust if needed.
4. Place the blind plugs into the holes.

Connect the mains power

Connect the cooker to either a single-phase or a three-phase power supply.



WARNING!

Risk of electric shock! Do not connect the product to the mains yourself. The product may only be connected by an authorised technician.



WARNING!

- The electrical installation must follow local regulations.
- For single-phase power supply, use a 3×4.0 mm² cord marked H05VV-F 3G4 or better.
- For three-phase power supply, use a 5×1.5 mm² cord marked H05VV-F 5G1.5 or better.
- Do not use external timers or separate remote control systems to control the product.



CAUTION!

Carefully read the instructions for use before connecting the appliance. Repair or any warranty claim resulting from incorrect connection or use of the product shall not be covered by the warranty.

Connect to a single-phase power supply

Follow these instructions to connect the cooker to a 220-240 V, 50-60 Hz, single phase power supply.

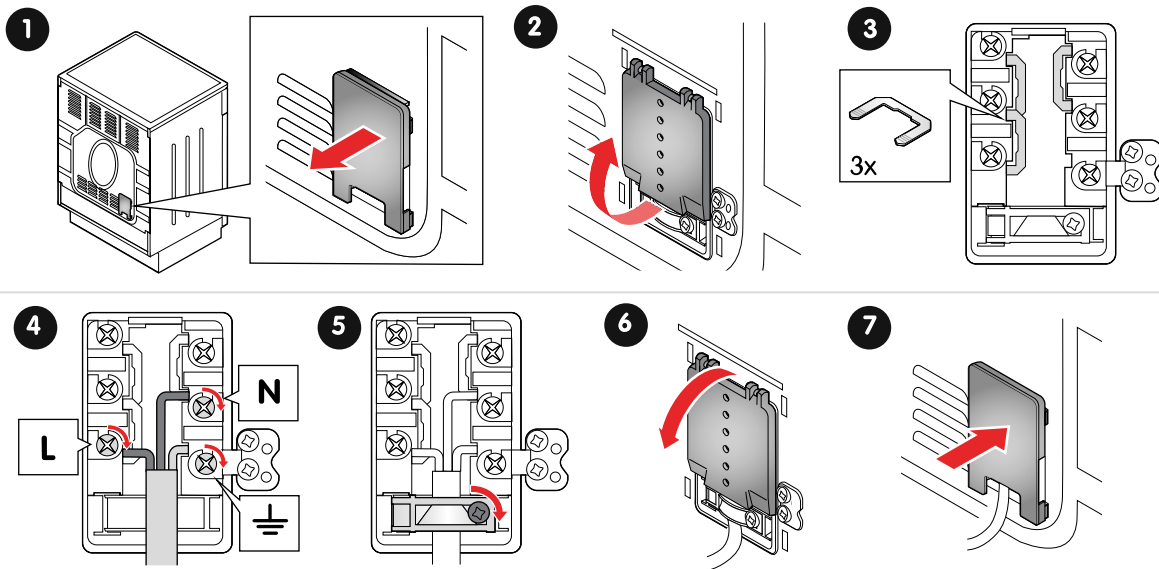

1. Remove the clamp protection cover.
2. Open the terminal board cover.
3. Install the bridges.
4. Secure the cable wires to the terminal board using the screws.
WARNING! Make sure the protective earth wire is properly secured.
5. Secure the cable with the clip.
6. Close the terminal board cover.
7. Install the clamp protection cover.

Connect to a three-phase power supply

Follow these instructions to connect the cooker to a 380-415 V 3N~, 50 Hz, three phase power supply.

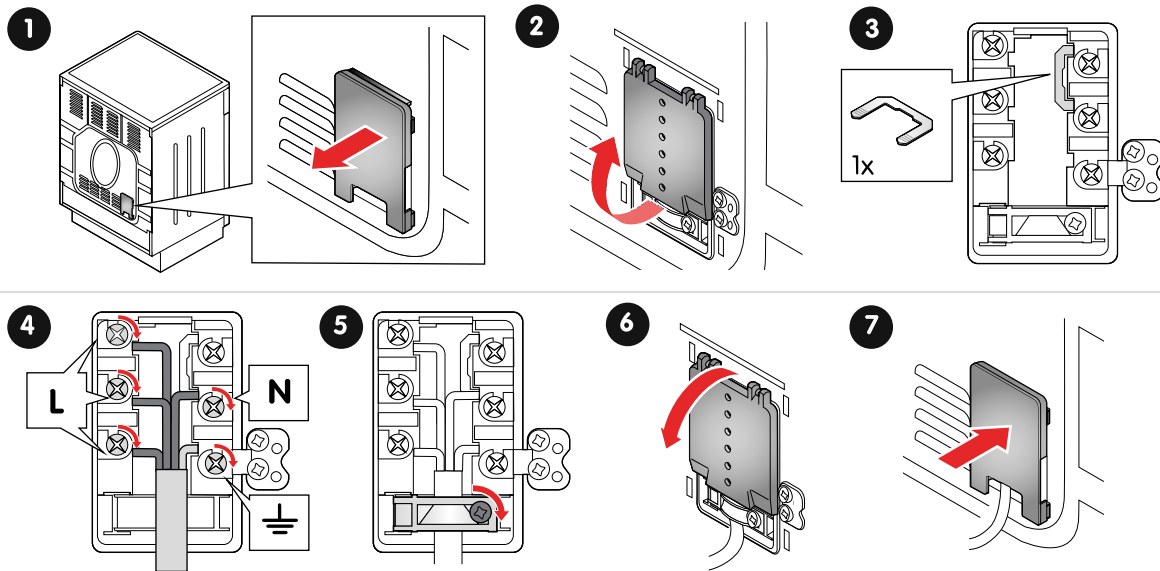

1. Remove the clamp protection cover.
2. Open the terminal board cover.
3. Install the bridge.
4. Secure the cable wires to the terminal board using the screws.
WARNING! Make sure the protective earth wire is properly secured.
5. Secure the cable with the clip.
6. Close the terminal board cover.
7. Install the clamp protection cover.

Do the following after the connection is completed

1. Make sure the mains power has been correctly installed.
2. Check that the heaters, control and governing elements are working correctly.

APPENDIX

Specifications

Product code	CGS3723V
Height	90 cm
Width	69.7 cm
Depth	59.4 cm
Weight	54.6 kg
Oven cavity volume	74 l
Power supply	220-240 V, 50-60 Hz 380-415 V 3N~, 50 Hz
Electrical connection rating	9 800 W

Cooking zone	Diameter	Power
Front left	22 cm	2 kW
Rear left	14.5 cm	1.5 kW
Rear right	18 cm	2 kW
Front right	14.5 cm	1.5 kW

EU directives and standards

This product fulfills the applicable EU directives and regulations and carries the CE mark. If not included with the product, a copy of the EU Declaration of Conformity is available on request.

The performance of this product complies with the standard EN 60350-1.

ELVITA



ELONGROUP

Elvita products are distributed and marketed by ELON Group AB.
Elon Group AB Bäcklundavägen 1 | 702 03 Örebro Sweden
ELON GROUP | +46(0)10-220 40 00 | ELONGROUP.SE
Support and service: ELVITA.SE